



# EKE

## Enhanced Surface Element Cooler

**OELTECHNIK** has developed, tested and continuously improved the EKE Element Intercooler product program in response to the needs of the compressor industry. Over decades the in-house developed software has been checked against actual test performance of our equipment.

**OELTECHNIK** has always taken challenges to extend the applications of the EKE Element Intercooler to serve our innovative customers' requirements.

**OELTECHNIK**'s products are successfully in use worldwide. Our design and fabrication capabilities are covering all international design codes and national regulations.

Feel free to approach us with your questions to our EKE Element Intercooler product.

The EKE Element Intercooler with enhanced surface finds its application where heat has to be transferred from a poor heat conducting fluid (e.g. gas) to a liquid fluid or vice versa. The liquid fluid is placed on the tube side and the gaseous fluid is on the shell.

The EKE Type heat exchanger allows with its enhanced outside tube surface to compensate the poor thermal conductivity of the gas. The gas flow is directed in one pass perpendicular through the enhanced tube bundle.

Even numbers of passes on the tube side are forming a combination of cross-flow and counter-flow which allows for temperature crosses of 5°C.

### Typical Fluids:

Shell Side: Wet air, dry air, Nitrogen, Oxygen, NH<sub>3</sub>, CO<sub>2</sub>, CO, CH<sub>4</sub>, and other gases.  
Tube Side: Water, Glycol, and water glycol solutions.

### Capabilities/Range of Application:

Design Pressure:	[2 - 90]	barg	[29 - 1305]	psig
Design Temperature:	[-25 - 200]	°C	[-13 - 392]	°F
Minimum Flow Rate:	[~ 7000]	Nm <sup>3</sup> /h	[~4 120]	scfm
Maximum Flow Rate:	Function of operating pressure and allowable pressure drop.			
Minimum Shell Diameter:	[800]	mm		
Maximum Shell Diameter:	[~3500]	mm		

### Material Combinations:

Tubes: 90/10 CuNi, 70/30 CuNi Admiralty, 304 SS, 316 SS, Duplex, Titanium and all other commercial available materials.

Fin: Aluminum, Cu, Stainless Steel, Steel.

Tube Sheets: Carbon steel, 90/10 CuNi solid, clad, Stainless steel, and all other commercial available plate materials.

Shell Side: Carbon steel, Stainless steel.

## Beneficial Features of EKE Element Intercooler:

- + Lowest Pressure Drops on gas side due to optimum flow guiding through the shell and the tube bundle of the intercooler. Energy consumption is minimized.
- + High Flexibility in Nozzle Arrangement, in- and outlet connections for the gas can be located in a wide range on the shell without limiting the heat transfer performance.
- + Internal Moisture Separation Device: For wet gas application the dew point might be reached which creates water knock out. The EKE Intercoolers allow for moisture separation devices inside of the shell.
- + Easy Bundle Removal: with or without the bundle removal device, the EKE Intercooler Bundle can be removed and inserted readily. Two stainless steel angle iron guide the brass roller pairs installed along the two lower edges of the bundle.
- + Stainless Steel Y-Seals with highest performance: A multiple layer stainless steel Y- shaped seal separates the hot and cold gas side. The seal type lasts several maintenance cycles.
- + Numerous options of enhanced surface: Due to the options of plate fin, helical high fin and bi-metallic high fin as means to provide enhanced surface, numerous combinations of fin and tube material are feasible.
- + No Chance of Vibration: The plate fin design connects all bare tubes with the fin to each other. The unsupported length is going towards zero. For the high fin tubing several spacer options are available. At the spacers' locations, rigid clamping bars are installed with adjustment features to optimise the tightening process.
- + Bundle removal device: A tool to remove and insert the bundle during maintenance can be designed upon customer's request. Adjustment options on this equipment allow to use one bundle removal device for a whole set of EKE Intercooler.

## Flow Arrangements :

The flow arrangements can be categorized into three major types: **B1**, **B2**, and **B3**

The Type **B1** Element Intercooler is specially designed for geared turbo compressors. It's featured to optimize cooling element and moisture separating device independently which can be very advantageous.

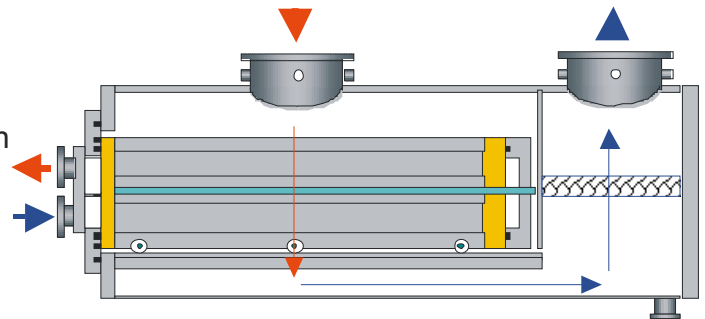
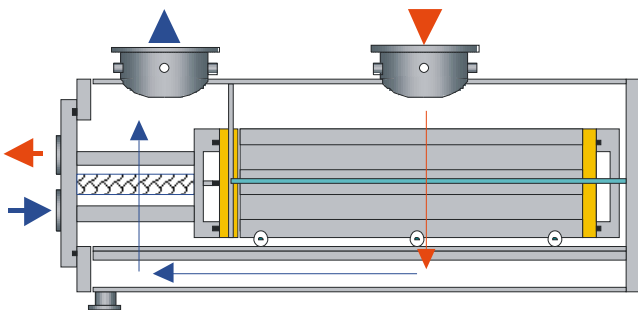

Due to the option to change the bundle location from front to back, an improved adjustment to the compressor design is granted. Nozzles can be inclined to the same side. The design criteria for moisture separation in a vertical flow apply. However the **B1** Type EKE Element Intercooler can be used also for dry gases. A set up turned 90° is also feasible.

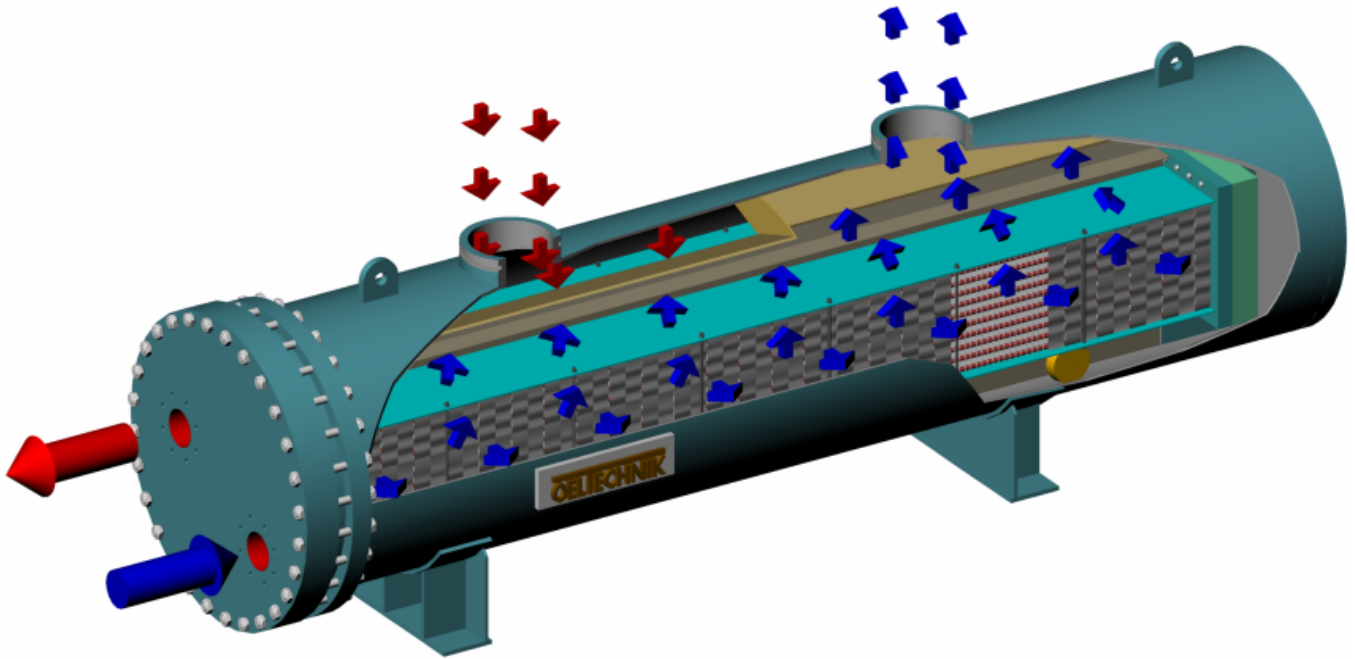

The Type **B2** EKE Intercooler is **OELTECHNIK**'s special design for high efficient cooling of dry gases. A square shaped tube sheet layout is created by an imaginary flipped tube bundle arrangement. This design allows to obtain small vessel diameters. However the advantageous cross- counter flow remains prevailing.

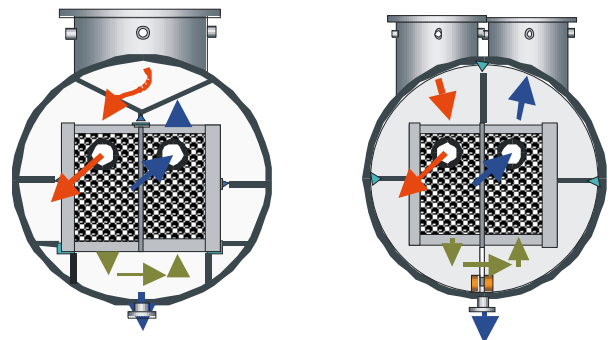
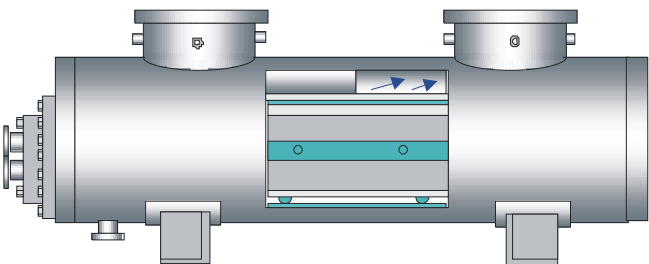

For medium size diameters and high shell diameter to bundle diameter ratios both nozzles can be placed on the centerline. Smaller shell to bundle clearance requires to offset inlet and outlet gas connections.

For increased flow rates it has to be examined whether the bundle Type **B3** is a superior solution.

Bundle

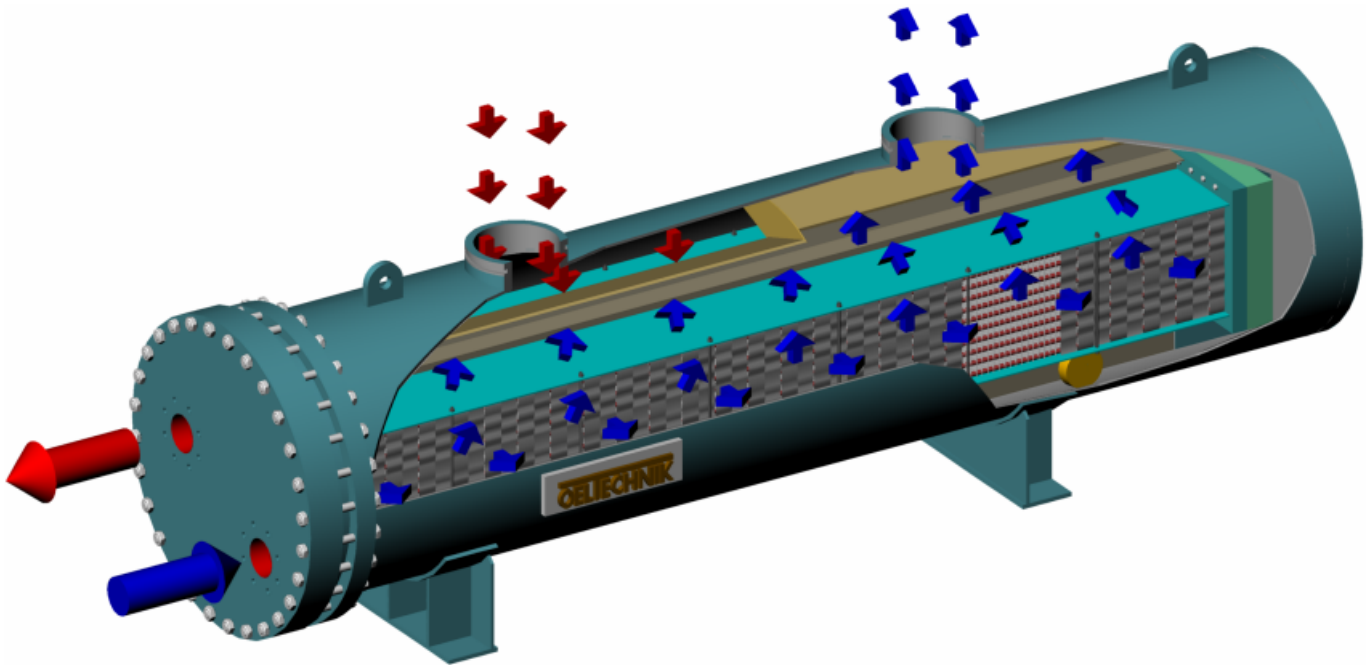

The Type **B3** Element Intercooler is **OELTECHNIK**'s standard bundle form for efficient cooling of wet and dry gases. The gas flow crosses the bundle in one pass. The flow cross sections are optimized by off-setting bundle and shell centerline to achieve the lowest pressure drop possible.

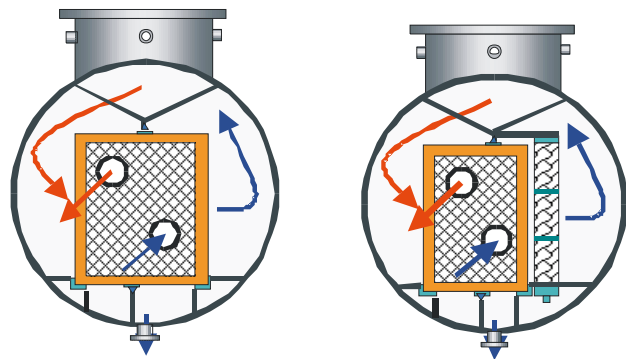

The nozzle locations can be chosen anywhere along the shell only limited by mechanical requirements. For wet gases a vertical demister can be installed to perform internal moisture separation. **OELTECHNIK** has developed and continuously optimized moisture separation devices for years. Separators designed by **OELTECHNIK** allow to cover the specified operating range.

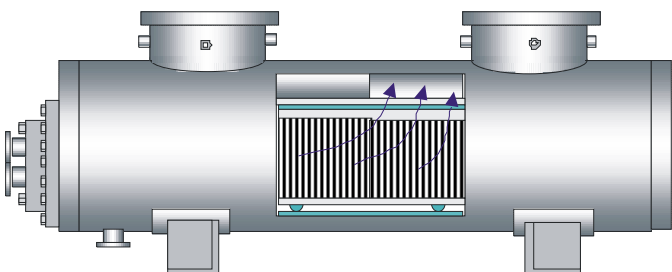

**OELTECHNIK**



The bundle type arrangements B1 and B3 allow for the installation of an internal moisture separating device. Selection and design of moisture separators is determined by the desired separation efficiency which is expressed for a certain droplet size. (e.g.:95% for droplets > 20 µm).

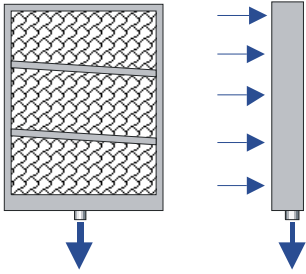

For the B3 Type EKE Intercooler demisters are installed on the gas outlet side of the bundle. A corrosion resistant wire mesh pad is placed in a stainless steel frame. Horizontally inclined gutters ensure the controlled guidance of collected condensate out of the gas stream to the bottom of the shell. From there it is drained out of the intercooler.

The vane type separator is another means to separate -moisture from the gas stream. **OELTECHNIK** designed and tested the contour of the vanes to optimize droplet separation in the gas stream.

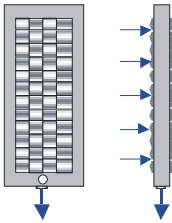
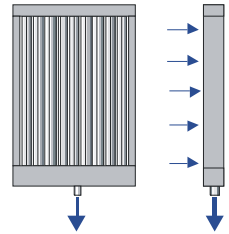

**OELTECHNIK's** wave plate separator is the most space efficient separator design. The waved strips force the gas stream to turn within a small radius. Higher inertial forces let the heavier condensate droplets impinge on the wave plate and drain down, while the gas passes through the waved plate.

## EKE Tube systems

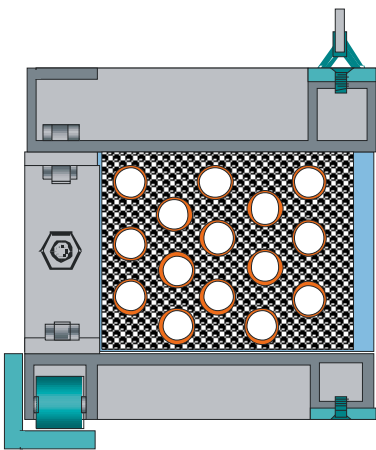

The EKE intercooler bundles show a rigid design. Brass rollers run on stainless steel guides which allow for easy bundle removal and insertion. Stainless steel Y- seals guarantee high performance and long life time. With the three options, plate fin, helical high fin, and Bi-metallic extruded high fin **OELTECHNIK** responds to your individual material requirements.

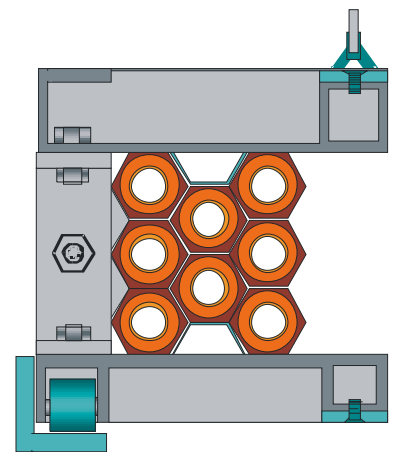

The continuous plate fin enhanced surface interconnects all tubes with each other. The compact packed bundle is fully resistant against vibration. **OELTECHNIK** has developed the plate fin corrugation to maximize the thermal performance of the fins.

Helical high fin or Bi-metallic tubes are provided with Hexagon Spacers in defined spacing. Clamping bars ensure a tight fit of the tubes to each other avoiding any form of vibration.

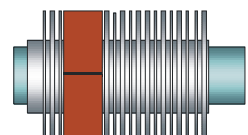
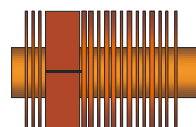
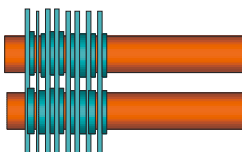

## Tube cleaning systems with brushes

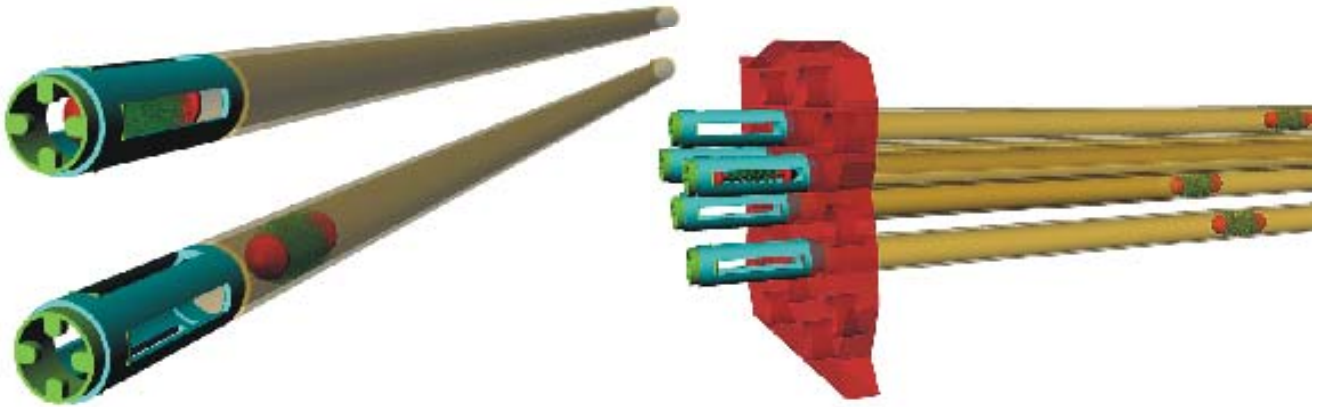

Biological and mineral fouling inside the tube have a significant negative effect on thermal performance of intercoolers. In order to reduce fouling inside the tubes, **OELTECHNIK** offers intercoolers with automatic brush cleaning. Decades of experience have proven that automatic brush cleaning is an efficient and economical method to clean liquid carrying tubes. The brushes are pushed through the tubes by the flow. The direction of the flow is normally reversed for about one minute every hour by automatic-control valves. Baskets installed on both ends keep the brushes from leaving the tube.

## Bundle Removal/Insertion Trolley



**OELTECHNIK** offers its in-house developed unique bundle trolley allowing for removal and insertion of the bundle on site without additional crane capacities. It assures proper handling of the bundle during maintenance. The bundle cart is adjustable for different shell and bundle sizes so that one trolley can be used for a whole train of EKE Element intercoolers.

# How to reach us

-  **OELTECHNIK** Headquarter
-  **OELTECHNIK** France
-  **TUBEITECH** GmbH

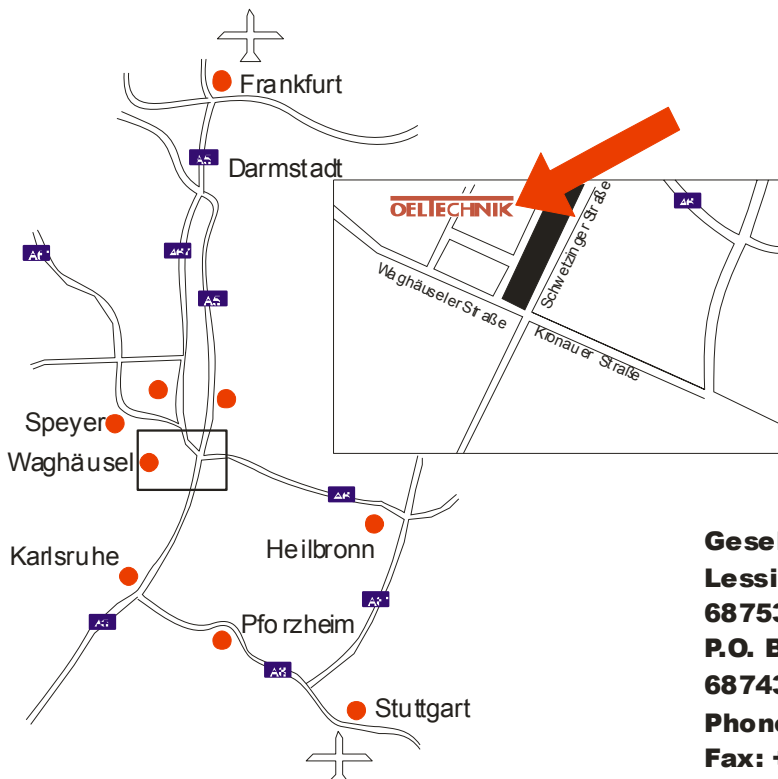

**Gesellschaft für Oeltechnik m. b. H.**  
**Lessingstraße 32**  
**68753 Waghäusel - Germany**  
**P.O. Box 1163**  
**68743 Waghäusel**  
**Phone: +4972549810**  
**Fax: +497254981105**  
**Internet: [www.oeltechnik.com](http://www.oeltechnik.com)**  
**e-mail: [zentrale@oeltechnik.de](mailto:zentrale@oeltechnik.de)**

**OELTECHNIK**